

Operating
and maintenance
manual for sliding
vanes vacuum pumps

Jurop
PORDENONE

Index

1. General advises

- 1.1 Introduction pag. 2
- 1.2 Request of spare parts pag. 2

2. Technical specifications

- 2.1 Overall dimensions vacuum pumps series R. pag. 3
- 2.2 Technical data and performances series R. pag. 4
- 2.3 Hydraulic transmission for mod. R...HDR pag. 5

3. Safe-operating prescriptions

- 3.1 General suggestions pag. 6
- 3.2 Normal running of the pump pag. 6

4. Installation

- 4.1 Checking at arrival of goods pag. 7
- 4.2 Pump mounting / Drive connection pag. 7
- 4.3 Layout of vacuum line pag. 8

5. Starting-up instructions

- 5.1 Oil level checking pag. 9
- 5.2 Lubrication checking pag. 9
- 5.3 Vacuum / Pressure changeover valve pag. 9

6. Maintenance

- 6.1 Ordinary maintenance pag.10
- 6.2 Extraordinary maintenance pag.10
- 6.3 Trouble-shooting pag.11

1. General advises

1.1 Introduction

This booklet contains the necessary instructions for a correct installation, running test, normal use and maintenance of the pump as well as practical suggestions for safe operating.

The knowledge of the following will give trouble free operation for a long time.

It is recommended to:

- read and apply closely the instructions before running the pump.
- keep the booklet at hand and have it known to all operators.

1.2 Request of spare parts

To avoid mistakes when ordering the spare parts make sure you indicate:

- | | | |
|----------------------------------|---|----------------------|
| a) the model of the pump | } | See pump label |
| b) the serial number of the pump | | |
| c) the denomination of the part | } | See spare parts list |
| d) the number of the pieces | | |
| e) the code of the part | | |

Example:

- a) R 260
- b) X60001
- c) Rotor vane
- d) N° 5 pc.
- e) 16016.042.00

2. Technical specifications

2.1 R series vacuum pumps-overall dimensions

Mod. R150 ÷ R200 ÷ R260

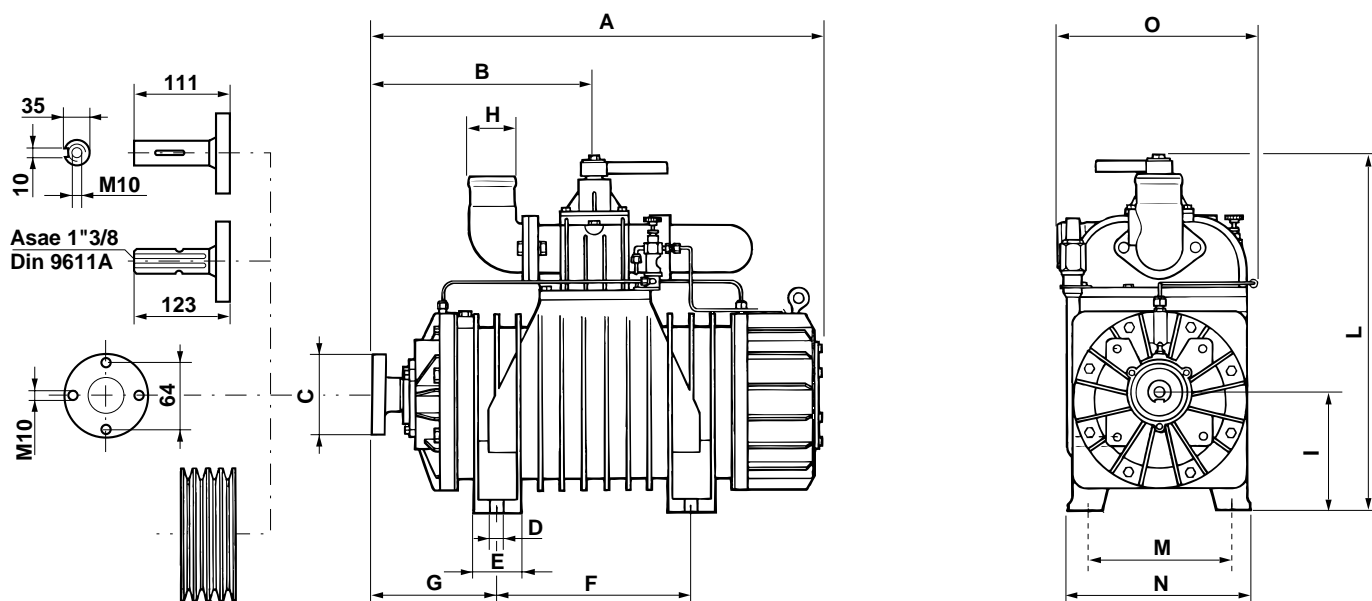

Mod. R430

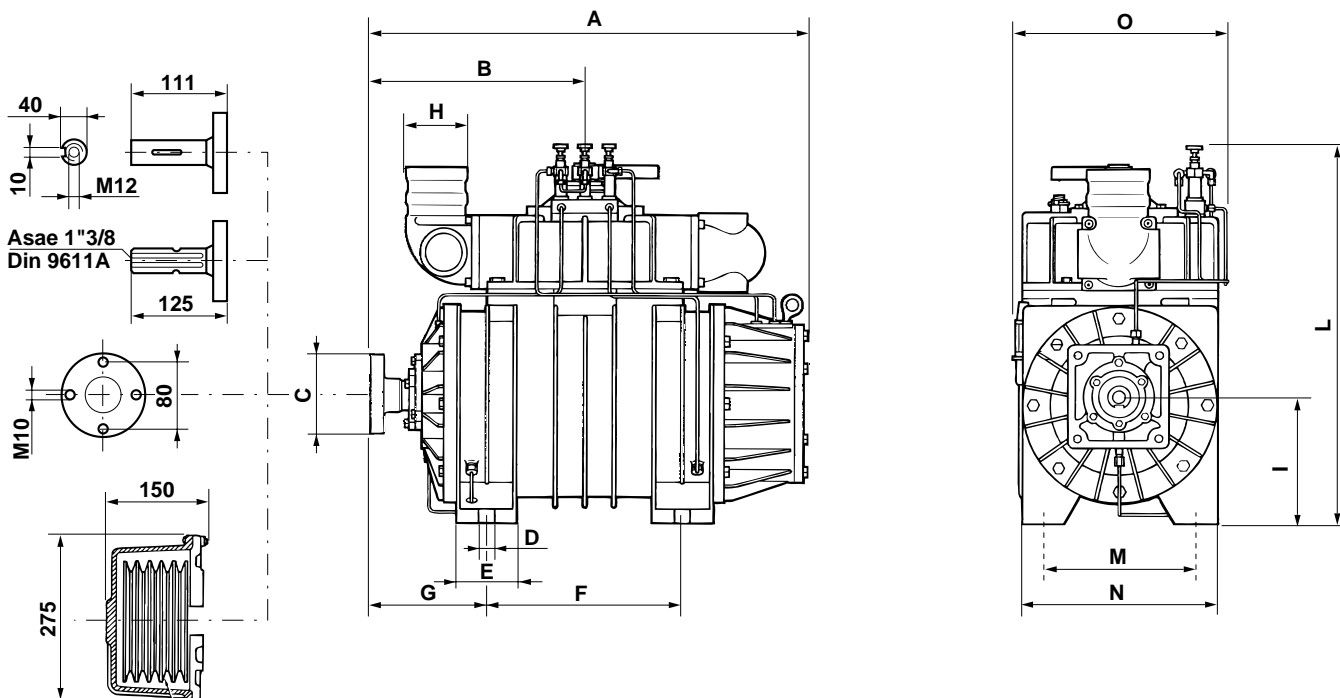

Dimensions in mm.

Model	A	B	C	D	E	F	G	H	I	L	M	N	O
R150	486	226	80	16	80	165	136	60/76/80	180	540	240	270	275
R200	586	276	80	16	60	290	130	60/76/80	175	515	240	270	275
R260	676	321	80	16	70	290	180	60/76/80	175	540	250	285	290
R430	650	300	102	16	95	300	150	100	210	590	275	320	320

2.2 Technical data and performances

The JUIOP sliding vanes vacuum pumps, R series, cooled by injection of air, are supplied complete with:

- High temperature **asbestos - free** vanes.
- Forced lubrication, oil tank.
- 4 ways vacuum/pressure changeover valve.
- Non-return check valve.
- Aluminum inlet/outlet connections.
- Splined shaft, smooth shaft or pulley.
- "Ballast Port" patented cooling by means of injection of air.

Upon request:

- Lubrication by means of automatic oil pump.
- Electric, hydraulic or auxiliary engine drive.
- Righthand (clockwise) or lefthand (counterclockwise) rotation

AIR COOLED VACUUM PUMPS SERIES R

Performances at 1200 R.P.M. - (max. speed)

Model		R150	R200	R260	R430
Air flow - l/min.	Free air	6000	8300	10300	12500
	60% vacuum	5000	6600	8600	10800
Max vacuum - %		92	92	92	92
Max absolute pressure - bar		1,5	1,5	1,5	1,5
Power at 1,5 bar absolute pressure - Kw		8,0	11,5	13,3	20,6
Weight - Kg.		125	145	180	190
Oil consumption g/h-drops/min total		90/50	115/65	135/80	150/95
Oil tank capacity - l.		2,3	2,3	2,3	4
Sound level at 60% vac. 7 m. dist. - dB (A) - with silencer		77	81	84	84

LIST OF RECOMMENDED OILS

Pump housing lubrication

Brand/Type	Environment temperature 5°± 30° C ISO 46 - SAE 20	Environment temperature > 40° C ISO 150
AGIP	Diesel sigma 5	Acer 150
B P	Venelus C3	Energol CS/50
ESSO	Essolube D3	Nuray 150
MOBIL	Delvac 1310	Vactra oil extra heavy
SHELL	Rinula	Talpa G150

2.3 Hydraulic transmission for mod. R...HDR

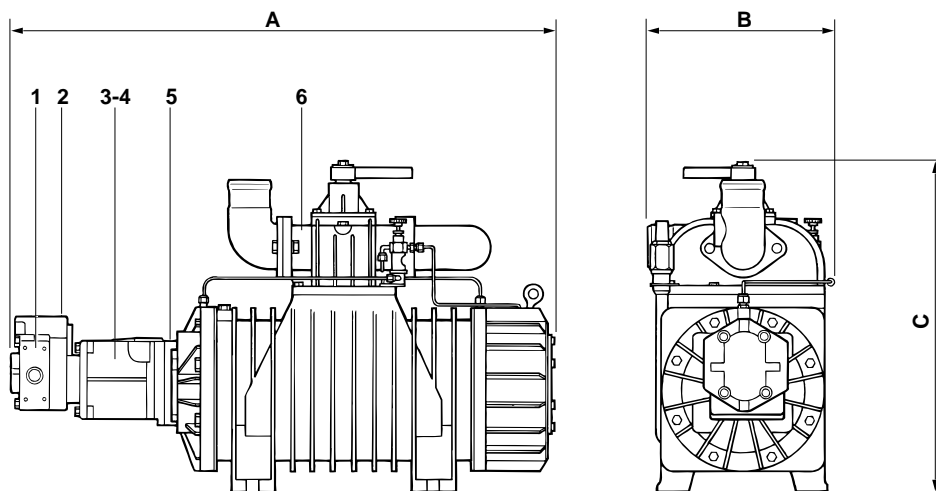

Legend

1 Hydraulic motor flange	4 Flexible joint
2 Hydraulic motor	5 Supporting flange
3 Supporting bracket	6 Vacuum pump

VACUUM PUMP MOD. R...HDR

Model	Characteristics of hydraulic motor			Dimensions in mm			Weight kg
	cc/rev	bar	r.p.m.	A	B	C	
R150-HDR	43,8	130	1200	720	275	540	155
R200-HDR	61,0	140	1200	830	275	515	178
R260-HDR	72,0	130	1200	920	290	540	215
R430-HDR	86,0	140	1200	910	320	590	225

3. Safe operating and accident prevention

3.1 General suggestions

- Ordinary and extraordinary maintenance has to be done while the unit is stopped and the drive disconnected.
- Interventions on pneumatic plants have to be done after disconnecting pressure/vacuum from the same.
- Never start the pump if adequate/foreseen safety devices are not installed.
Damaged protections must be immediately replaced.
- Be aware that during operation the pump's body can reach temperature of over 60° centigrade.
Possibility of burnings if this warning is missacted.



Maximum speed shown in the technical specifications tables must not be exceeded.

3.2 Normal use

- Vacuum pumps of the R-series used for the suction of liquids are foreseen for a max pressure of + 1,5 bar and a max vacuum rate of 92 %.
As cooling is given by atmospheric plus forced air, pumps are foreseen for non-continuous duty.
Overheating of the pump will cause serious damage of the same and/or blocking of the rotor.
In order to the maximum efficiency of the forced air cooling system the filters of the injection valves must be kept clean.(fig. 1)

Fig. 1

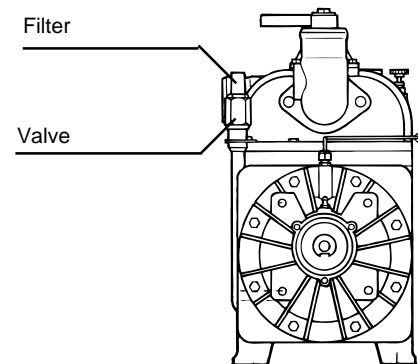

4. Installation

4.1 Checking at arrival

- upon receipt check that the pump and related accessories are not damaged.
- Check that the rotor/shaft is not blocked.

4.2 Pump mounting / Drive connection

- The pump must be installed so that it is easily accessible for inspection and maintenance.
- The vacuum pump must be installed on a rigid base or stand. The drive can be by cardan shaft, belts and pulley or by hydraulic motor.
- The cardan shaft must be mounted so that it does not create any axial thrust; the inclination of the shaft must not exceed 15° (see fig. 2).
- When using the belts and pulley, the pulley can be mounted directly on the rotor shaft except for R 430 . For model R 430 pumps the pulley must be mounted with the suitable support, supplied by JUROP. The alignment between the pulley of the pump and the driving pulley must be thoroughly checked. The V-belts tension must be normal, that means the belts must flex for about 2 cm. under the thumb pressure.
- With the hydraulic transmission the motor must be connected by means of a support and a flexible joint.



The transmission must be protected according to current safety standards (for Europe 89/392 CEE standards).



Check that the actual shaft rotation direction matches that of the arrow on the label fixed on the front of the pump.

Fig. 2

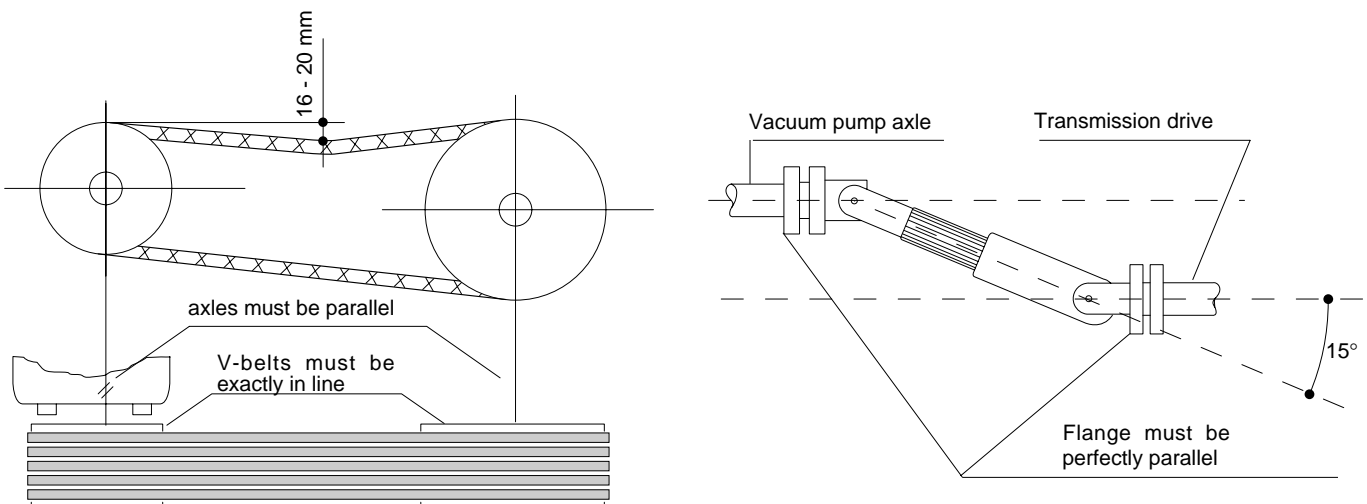

4.3 Layout of vacuum line

Fig. 3

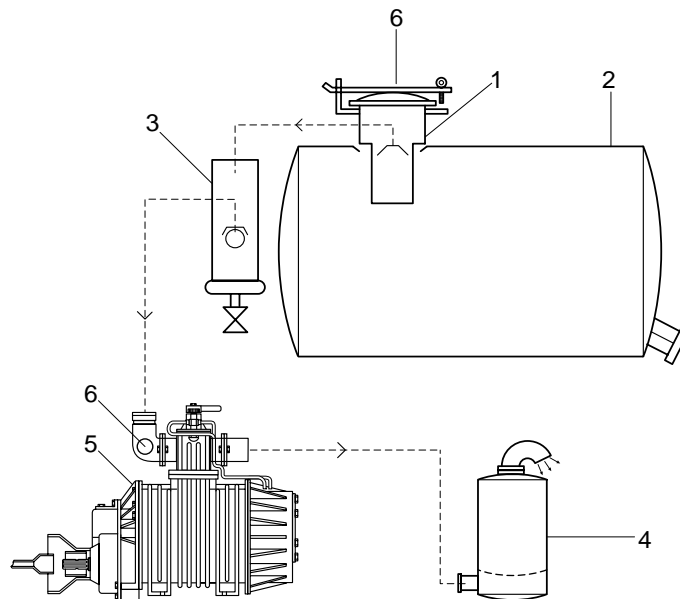

"R" PUMP WITH STANDARD MANIFOLD

Legend

- | | |
|---|---------------------|
| 1 | Primary shutoff |
| 2 | Tank |
| 3 | Secondary shutoff |
| 4 | Silencer + oil trap |
| 5 | Vacuum pump "R" |
| 6 | Safety relief valve |

- The mounting of a secondary shutoff (pos. 3) is suggested, in-between the pump and the tank, for protecting the vacuum pump.
- A silencer (pos. 4) is suggested in order to reduce sound level.



The application of a safety relief valve and a vacuum relief valve on the tank or along the suction line must be foreseen.

5. Starting-up instructions

5.1 Oil level checking

- Before starting-up the pump, check by the oil dip-stick the level of the oil (fig. 4). If refill is needed only the recommended oils must be used (see page 4)

Fig. 4

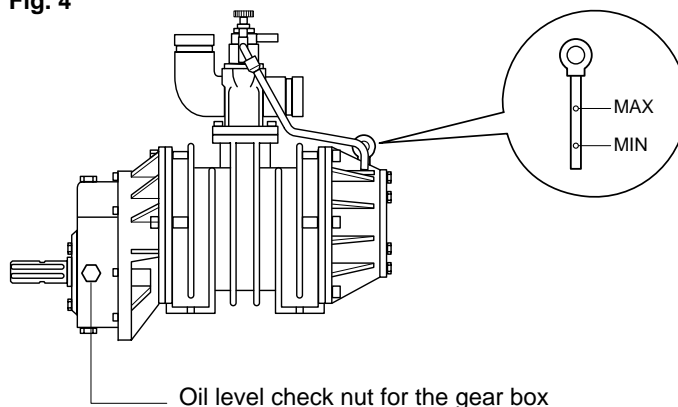

5.2 Lubrication checking

- When the pump is running, check the correct flow of the oil through the sight glasses of the drip oilers (oil drops must flow regularly).
In case of adjustment of oil, the drops must be at least in number

of 30 a minute in each drip oiler (oil flow will increase by turning the adjusting pin on the drip oiler counterclockwise and will decrease by turning it clockwise).
For oil consumption see page 4.

5.3 Vacuum / Pressure changeover valve

- Rotating the handle of the 4 way valve (pos. 1÷2 - See following figure) the pump changes over from vacuum to pressure (or viceversa).



As the pump can be connected to the vacuum tank with both the front (drive side) connection or the rear (oil tank side) connection in order to avoid mistakes see the following table "Vacuum-Pressure"

Manifold	Drive	Handle pos.	Pump function	Connection to the tank
Standard	Direct drive Left	1	Pressure	
	Gear box Right	2	Vacuum	
	Direct drive Right	1	Vacuum	
	Gear box Left	2	Pressure	
Mixer	Direct drive Left	1	Vacuum	
	Gear box Right	2	Pressure	
	Direct drive Right	1	Pressure	
	Gear box Left	2	Vacuum	

- JUROP pumps are normally assembled to be connected to the tank by the front connection (see fig. 3 page 8).

- **Left** hand drive means counterclockwise rotation and **Right** hand drive means clockwise rotation, looking at the pump from the shaft side.



In case the pump is connected to the tank with the rear connection (oil tank side) the functions "Vacuum - Pressure" will be reversed.



Be aware not to place the handle in neutral position (half way between the two end positions) otherwise the pump will be by-passed (actually runs idle)

6. Maintenance

6.1 Ordinary maintenance

- Re-fill periodically the lubrication oil tank.
- Clean the sight-glasses of the drip-oilers.
- Check that the drive protections are properly fixed.
- On direct-drive models grease the front bearing (pos. 1 - fig.5)
- Clean the filters of the injection valves (ballast ports).

6.2 Extraordinary maintenance

Changing of the sliding-vanes:

- Remove the front flange as shown in fig. 5.
- Lubricate the new vanes and insert them after removal of the old ones.
- Replace all the gaskets and seals (ask for the suitable "Gasket kit").

Checking of vanes wear

The wear of the vanes can be checked without taking apart the pump.

Unscrew the plug (fig. 6) and insert a rod of dia. 6 mm. and turn the shaft by hand. With the checking rod touching the outside diameter of the rotor, mark it a first time with a scribe.

Fig. 5

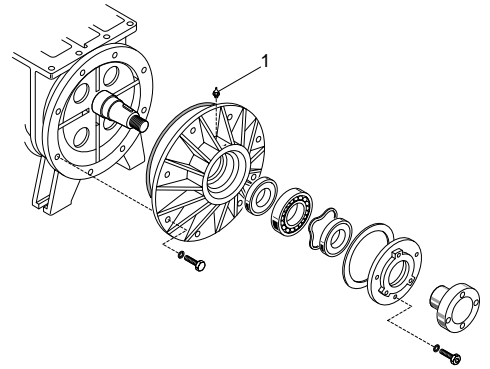

Continue turning the shaft till the checking rod falls inside a vane groove touching the vane.

Mark the rod a second time. If the distance between the two marks exceeds 5 mm. the vanes must be replaced (see fig. 7).

Once finished the checking procedure replace the plug of fig. 6.

Fig. 6 - R150 - R200 - R260

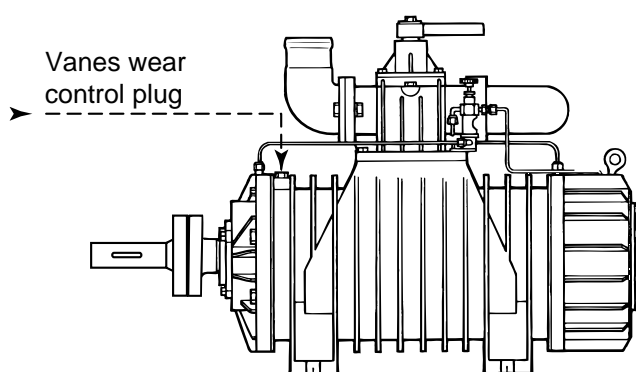

Fig. 6 - R430

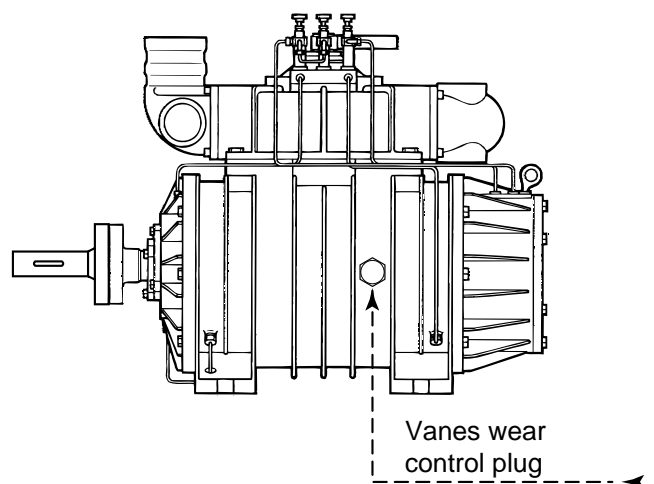
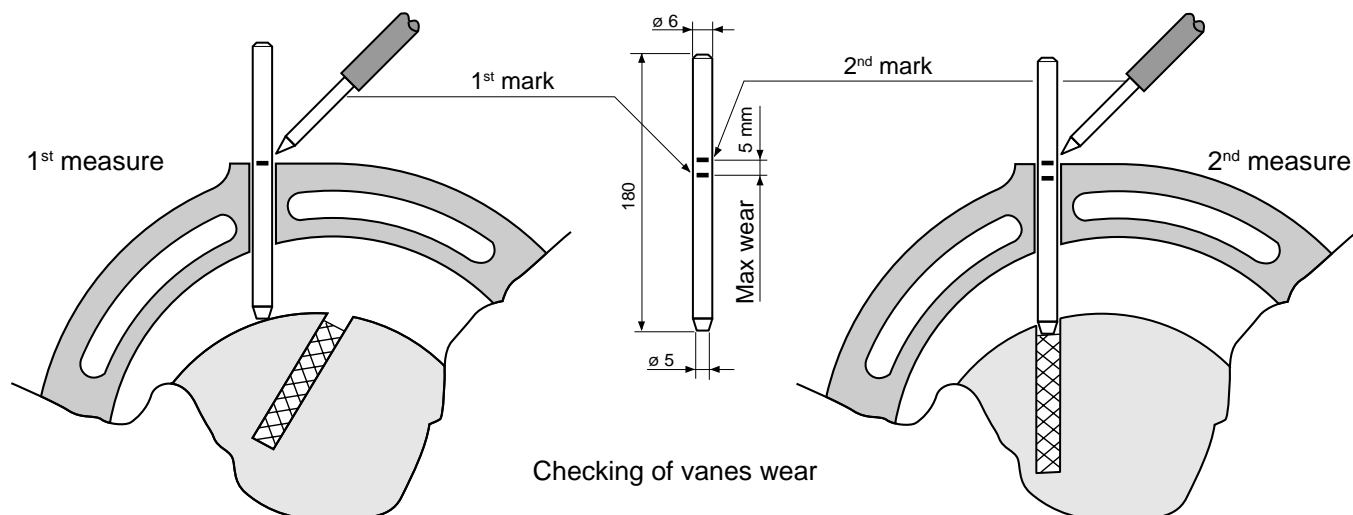

Fig. 7



6.3 Trouble-shooting

Troubles

A - Overheating of the pump

CAUSE	CORRECTION
- Faulty lubrication	- Check the lubrication
- Oil missing	- Re-fill the tank
- Revs. to high	- Reduce revs.
- Operation-time too long at too high vacuum	- Stop the pump for a while and let it cool down or operate at lower vacuum rate
- Clogged filters of "ballast port" injection valves	- Clean thoroughly the filters

B - Pump consumes too much oil

CAUSE	CORRECTION
- Drip-oiler/s badly adjusted	- Adjustment as described
- Oiler's pin not sealing	- Clean the related seat

C - The pump is blocked

CAUSE	CORRECTION
- Broken vanes due to suction of foreign objects or bad lubrication	- Dismount the pump and replace damaged parts. Check primary shut-off and lubrication system.
- Frozen pump	- Unfreeze the vacuum pump
- Damaged drive system	- Check and replace damaged parts
- Flange bolts to tight	- Loosen the bolts

D - Little or no vacuum or pressure in the tank

CAUSE	CORRECTION
- Change-over lever in neutral position	- Place lever in right position as shown at point 5-3.
- Worn sliding-vanes	- Replace the vanes
- Loose check-valve	- Replace the valve
- Worn sealing rings	- Replace the rings
- Blocked vacuum pump	- See previous instructions
- Leaking of the gate-valves on the tank	- Tighten the valves
- Leaking of the seals on the tank	- Repair or replace the seals
- Primary shut-off blocked	- Dismount and clean the parts
- Clogged connecting pipeline	- Clean the steel pipelines or replace the rubber ones