

# 10 GALLON HORIZONTAL SECONDARY SHUTOFF

PART#	DESCRIPTION	L x W x H	WEIGHT
1008-0102	10 GAL HORIZONTAL SECONDARY, 3" OPENING , (400 CFM)	22.2 x 16 x 16	109LBS

**CAPABLE OF HANDLING 400 CFM**



**NEW Design**

- Gasket In The Lid Design
- 3 - Wing Nut Easy Access
- Tested From 0 - 400 CFM
- 1" Ball Valve Drain
- Weight 72 Lbs.
- Under The Catwalk Installation
- Dual Rear Mounting Brackets
- 6" Stainless Steel Float Ball
- 3" Rubber Shutoff Seat
- Heavy Duty Ball Cage

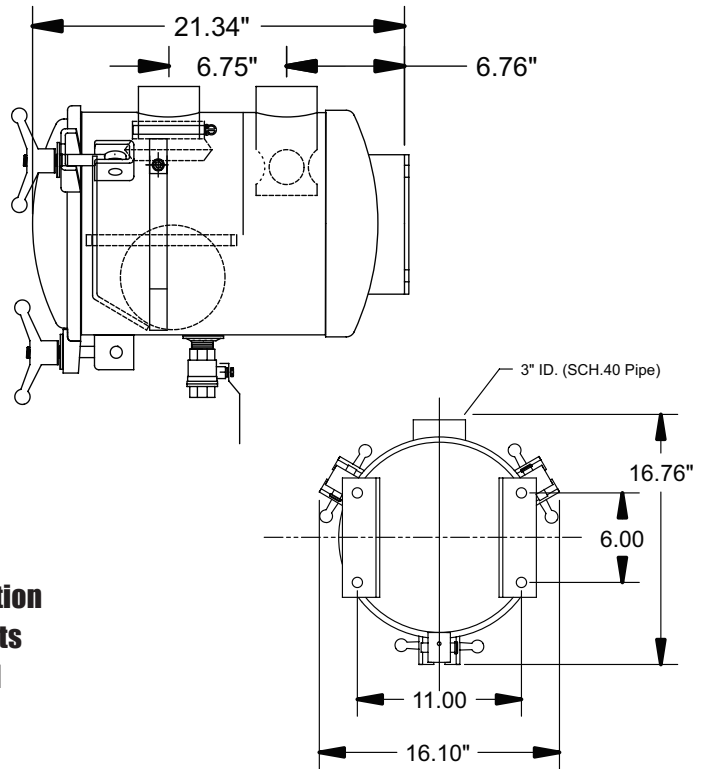

#	PART#	REPLACEMENT PART DESCRIPTION
1	1008-0112	10 GAL.HORZ.BODY WELDMENT
2	1010-0001	5/8" WING NUT
3	1010-0003	ZINIC MANWAY WASHER
4	1021-0000-P	ZINIC PLATED CLEVIS PIN
5	1021-0000-R	ZINIC PLATED ROLL PIN
6	1021-0000-B	5/8" X 5" EYEBOLT
7	1010-5010	12" LID ASSY.(GSK-LID TYPE)
8	1019-0008	GASKET FOR 12"HATCH,G-LID
9	1090-0001	HOSE CLAMP (3"SIZE RUB.SEAT)
10	1090-0000	3"RUB.SEAT FOR 3"SCH.40 PIPE
11	1076-0000	6"STAINLESS STEEL FLOAT BALL
12	1014-0007	CAGE WELD TAB
13	1000-0138	3/8" X 1" CAP SCREW
14	1000-0118	3/8" LOCK WASHER
15	1000-0168	3/8" HEX NUT
16	1008-0113	BALL CAGE, 10 GAL.HORZ.
17	1001-0020	1" CLOSE NIPPLE
18	1037-0001	1" BRASS BALL VALVE

