

# REAR DOOR LATCHES

**DESIGNED FOR USE ON  
REAR OPEN DOORS**

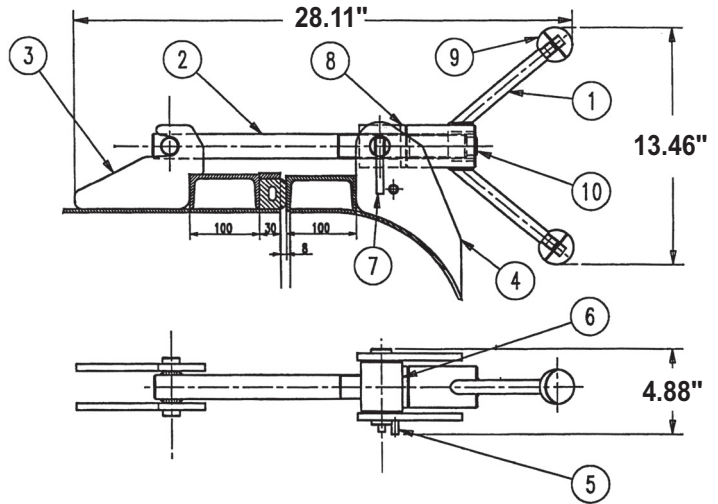

**HEAVY DUTY STEEL  
CONSTRUCTION**



#	PART#	DESCRIPTION
REPLACEMENT PARTS		
1	1505000200	WING NUT
2	1571000400	THREADED T-BOLT
3	1613001800	LOWER STEEL BRACKETS
4	1613001900	UPPER STEEL BRACKET
5	1622002100	SHAFT
6	1636000000	STOPPING PIECE
7	1681003500	DISC
8	1685600000	NYLON WASHER
9	4025510030	GRIP KNOB
10	4026415021	PIN 6 X 55

PART#	DESCRIPTION	WEIGHT
1830000100	REAR OPEN DOOR LATCH ASSEMBLY, COMPLETE	26LBS