

STEEL PRIMARY SHUTOFFS

PART#	DESCRIPTION	L x W x H	WEIGHT
1033-0001	STEEL PRIMARY WITH 2" OPENING, (130 CFM)	9 x 9 x 16	19LBS
1034-0001	STEEL PRIMARY WITH 3" OPENING, (250 CFM)	9 x 9 x 16	23LBS

AVAILABLE WITH 2" OR 3" SIZE OPENINGS

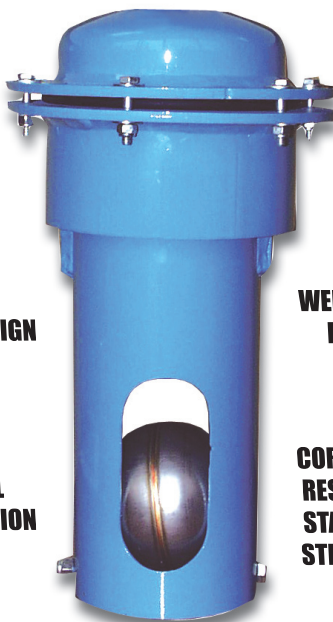

**6 BOLT
FLANGE DESIGN**

**WELDABLE BASE
IS 6.5" O.D.**

**ALL STEEL
CONSTRUCTION**

**CORROSION
RESISTANT
STAINLESS
STEEL BOLT**

**4" STAINLESS STEEL FLOAT
BALL FOR POSITIVE SHUTOFF**

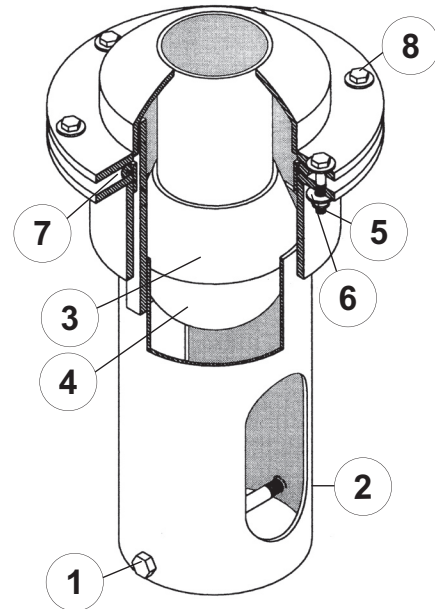
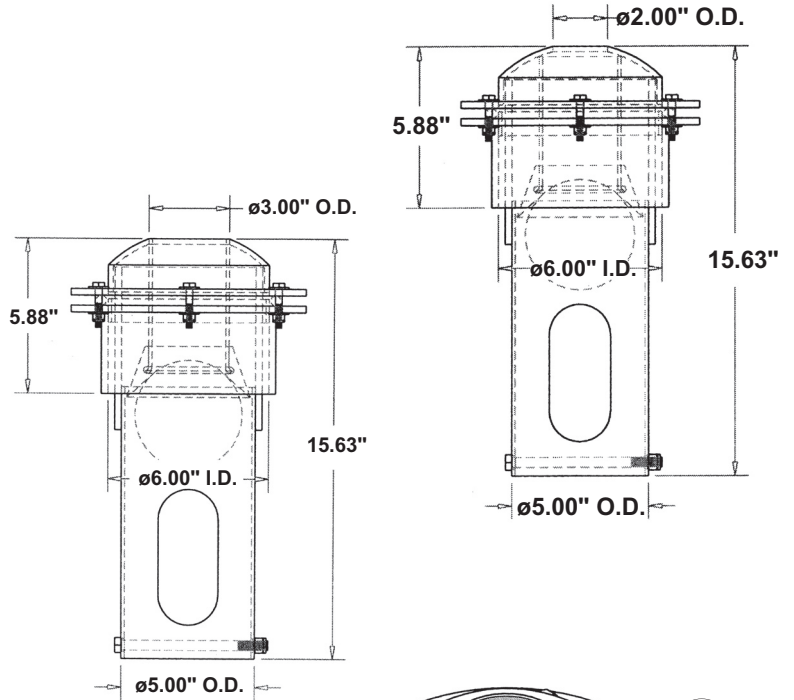

#	PART#	DESCRIPTION
REPLACEMENT PARTS		
1	1000-0144-004	3/8"-16 X 5.5" SS CAP SCREW
2	1000-0144-005	3/8" SS LOCK NUT
3	1089-0000	3" RUBBER SEAT
4	1075-0000	4" STAINLESS STEEL FLOAT BALL
5	1000-0100	1/4" LOCK NUT
6	1000-0108	1/4" FLAT WASHER
7	1033-1000	GASKET FOR STEEL PRIMARY
8	1000-0126	1/4" X 1 1/2" CAP SCREW