

REAR DOOR LATCHES

**DESIGNED FOR USE ON
REAR OPEN DOORS**

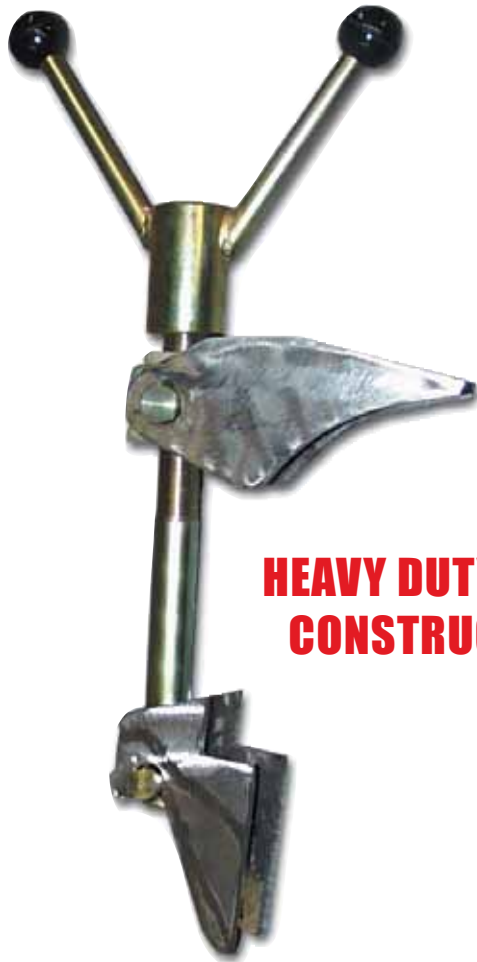

**HEAVY DUTY STEEL
CONSTRUCTION**

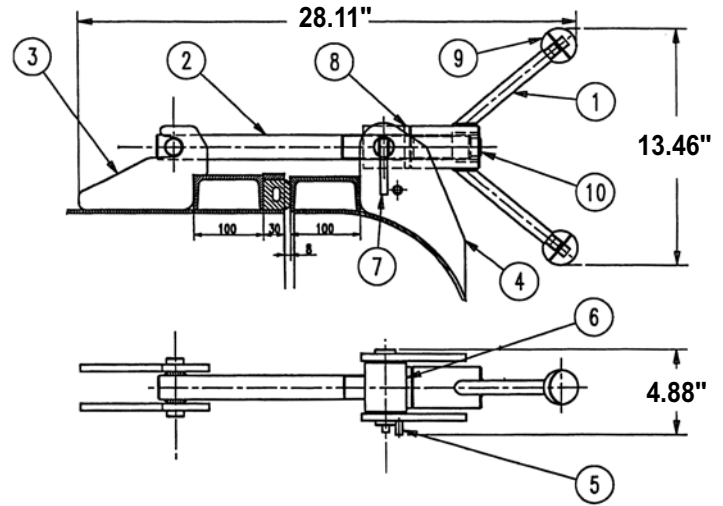

REAR DOOR LATCHES

| # | PART# | DESCRIPTION |
|-------------------|------------|----------------------|
| REPLACEMENT PARTS | | |
| 1 | 1505000200 | WING NUT |
| 2 | 1571000400 | THREADED T-BOLT |
| 3 | 1613001800 | LOWER STEEL BRACKETS |
| 4 | 1613001900 | UPPER STEEL BRACKET |
| 5 | 1622002100 | SHAFT |
| 6 | 1636000000 | STOPPING PIECE |
| 7 | 1681003500 | DISC |
| 8 | 1685600000 | NYLON WASHER |
| 9 | 4025510030 | GRIP KNOB |
| 10 | 4026415021 | PIN 6 X 55 |
| | | |
| | | |
| | | |

| PART# | DESCRIPTION | WEIGHT |
|------------|---|--------|
| 1830000100 | REAR OPEN DOOR LATCH ASSEMBLY, COMPLETE | 26LBS |
| | | |
| | | |
| | | |