

2", 3", 4" & 5" VERTICAL OIL CATCH MUFFLER/OIL SEPARATORS



PERFORATED STAINLESS STEEL MESH TO CATCH OIL AND QUIET PUMP NOISE



1002-0200



1002-0400



1002-0600



1002-0019

- **UNIQUE CYCLONE INTAKE & AIR Baffle SYSTEM**
- **NO NEED FOR 2 SEPARATE UNITS**
- **130-1165 CFM CAPACITY**
- **3/16" STEEL CONSTRUCTION**

PART#	DESCRIPTION	L x W x H	WEIGHT
1002-0150	1.5" VERTICAL OIL CATCH MUFFLER (130 CFM) 1.5"NPT	6 x 7.5 x 17	15 LBS
1002-0200	2" VERTICAL OIL CATCH MUFFLER (130 CFM) 2" TUBE	6 x 7.5 x 17	15 LBS
1002-0201	2" VERTICAL OIL CATCH MUFFLER (130 CFM) 2" NPT	6 x 7.5 x 17	16 LBS
	ABOVE MUFFLERS INCLUDE 1 1/2-2" NPT OR TUBING IN & 2" O.D. TUBING OUT		
1002-0400	3" VERTICAL OIL CATCH MUFFLER (400 CFM) 3" FML NPT	12 x 12 x 22	50 LBS
	ABOVE MUFFLERS INCLUDE 3" NPT FEMALE THREADS ON TOP AND SIDE		
1002-0600	3" VERTICAL OIL CATCH MUFFLER (600 CFM) 3" TUBE	12 x 12 x 34	59 LBS
1002-0601	4" VERTICAL OIL CATCH MUFFLER (600 CFM) 4" TUBE	12 x 12 x 34	61 LBS
1002-0602	3" VERTICAL OIL CATCH MUFFLER (600 CFM) 3" NPT	12 x 12 x 34	62 LBS
1002-0603	4" VERTICAL OIL CATCH MUFFLER (600 CFM) 4" NPT	12 x 12 x 34	66 LBS
	ABOVE MUFFLERS INCLUDE 3-4" NPT OR TUBING IN AND 4" SIZE TUBING OUT		
1002-0019	SILENCER - OIL SEPARATOR (700 CFM) 4"	14 x 13 x 40.74	95LBS
1002-0020	SILENCER - OIL SEPARATOR (1165 CFM) 5"	14 x 13 x 48	100LBS

2", 3", 4" & 5" VERTICAL OIL CATCH MUFFLER/OIL SEPARATORS

VERTICAL MUFFLERS

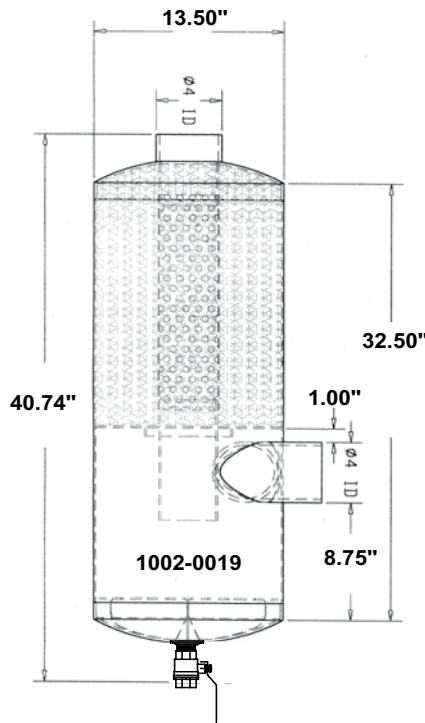
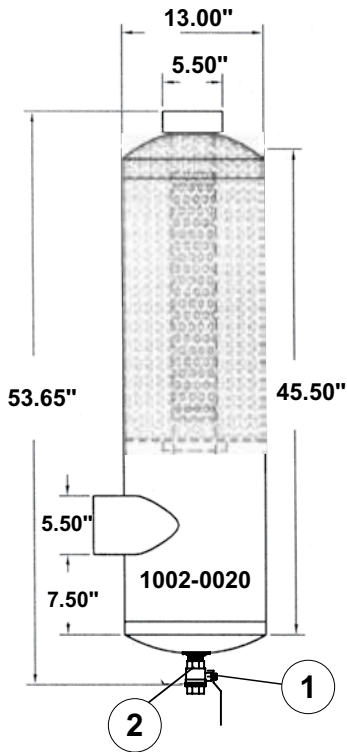
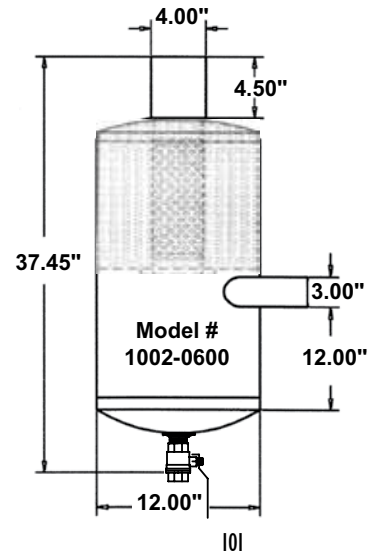
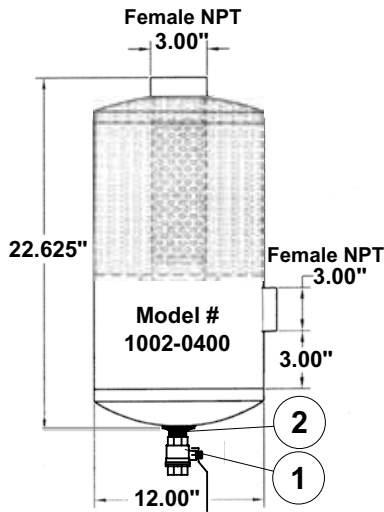
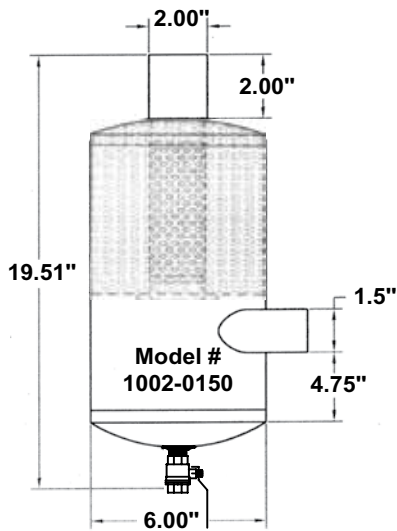

PERFORATED STAINLESS STEEL MESH TO CATCH OIL AND QUIET PUMP NOISE

CLEANING

NOTE: All mufflers can be cleaned by removing from system and high pressure washing.

#	PART#	DESCRIPTION
REPLACEMENT PARTS		
1	1037-0001	1" BRASS BALL VALVE
2	1001-0020	1" CLOSE NIPPLE

