

RV520 VACUUM PUMP

NEW!

RV SERIES VACUUM PUMPS

FEATURES:

- 520 CFM @ FREE AIR
- 24" CONTINUOUS DUTY
- HI-EFFICIENCY DUAL FAN AIR COOLED
- AUTOMATIC LUBRICATION
- INDEPENDENT SIDE MOUNTED OIL TANK
- INTEGRATED 4-WAY VALVE MANIFOLD

Jurop
NORTH AMERICA



For filter assembly, add either:

CEI Filter 1007-1004
Jurop Filter 185212L4B0

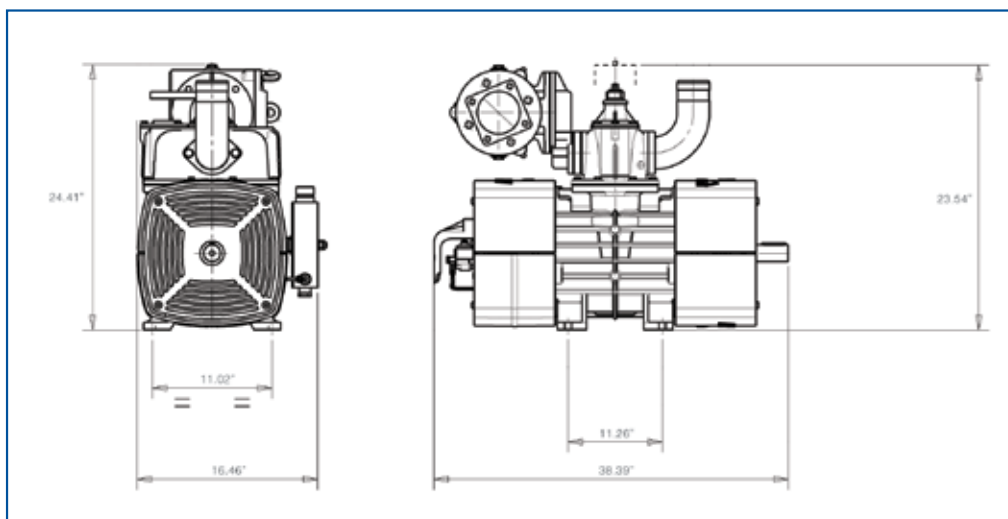

RV520 SPECIFICATIONS

RPM Range	1200-1300
Max Vacuum	28" / 92%
CFM @ Free Air	520
CFM @ 18"	466
Max Intermittent Pressure	30 PSI
Horsepower	23
Noise @ 18"	76 dB
Oil Tank Capacity	1 gallon
Net Weight	540 lbs
Recommended Oil	ISO 150
40mm Smooth Shaft	



Phone **1-800-342-0887** | Fax **1-888-645-9700**
Due to unforeseeable market fluctuations, prices are subject to change without notice.