

BRASS VACUUM RELIEF VALVES

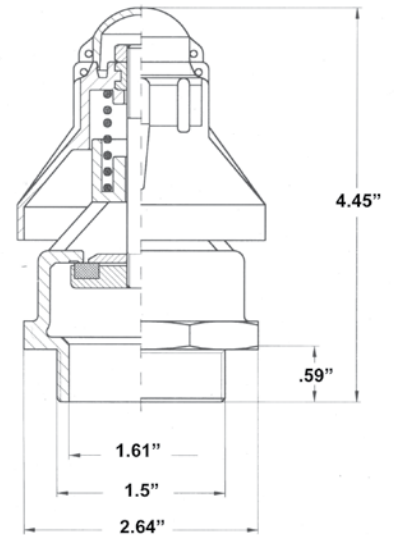

ADJUSTABLE

- **DURABLE BRASS CONSTRUCTION**
- **AVAILABLE IN 1 1/2" SIZE**
- **RATED AT 370 CFM FLOW**



PART#	DESCRIPTION	WEIGHT
1035-0000 MZ	1 1/2" BRASS VACUUM RELIEF VALVE, (370 CFM)	1 LBS
1035-0001 MZ	REPLACEMENT CAP	

BRASS PRESSURE VALVES



- **DURABLE BRASS CONSTRUCTION**
- **SIZES RANGING FROM 1-1/4 TO 2 INCHES**
- **PRESSURE RANGE FROM 155 TO 300 CFM**
- **FULLY ADJUSTABLE**

DIMENSIONS				
	0"	1.25"	1.5"	2"
0l	1.26"	1.57"	1.9"	
d	1.3"	1.46"	1.7"	
D	1.54"	1.73"	1.93"	
h	1.8"	1.93"	2.01"	
H	7.7"	7.7"	7.7"	
L	1.1"	1.18"	1.42"	
L1	1.13"	2.36"	2.52"	

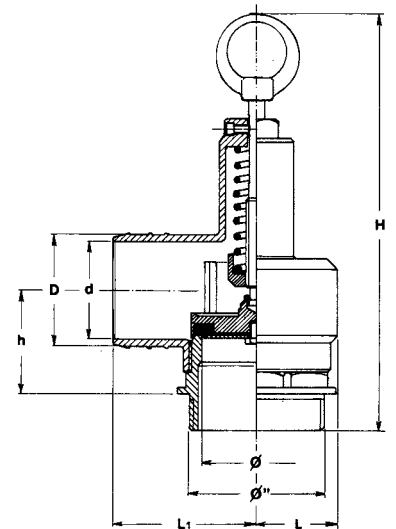

PART#	DESCRIPTION	WEIGHT
1048-0000 MZ	1 1/4" BRASS PRESSURE VALVE - (155 CFM)	2LBS
1049-0000 MZ	1 1/2" BRASS PRESSURE VALVE - (230 CFM)	2LBS
1050-0000 MZ	2" BRASS PRESSURE VALVE - (300 CFM)	3LBS
1050-0001 MZ	REPLACEMENT RING	

www.chandlerequipment.com

Due to unforeseeable market fluctuations, prices are subject to change without notice.

SAFETY VALVES - VACUUM RELIEF VALVE SETTINGS

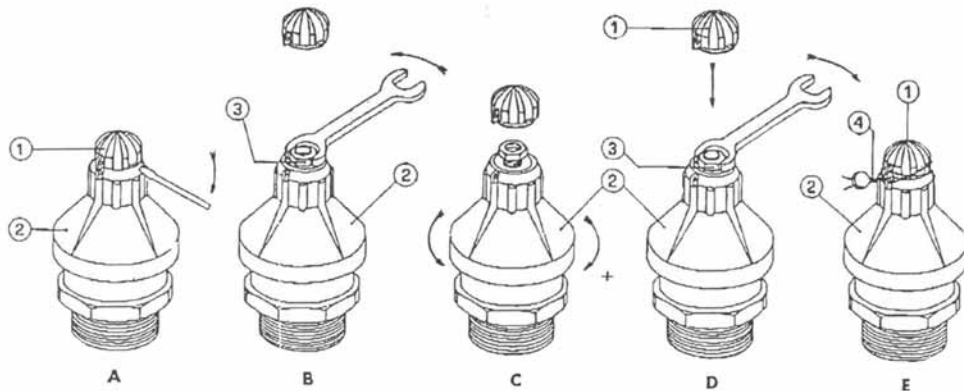

VACUUM RELIEF VALVE SETTINGS

- A) Take off cover (1) from the adjusting bell (2) by using the point of a screwdriver in the special incision.
- B) Loosen the stop set nut (3) by firmly holding the adjusting bell (2).
- C) Regulate the pressure on the spring by turning the adjusting bell (2). Turn clockwise to increase the pressure and turn anti-clockwise to reduce it. During this operation it is necessary to avoid the rotation of the stem acting with a screwdriver in the special incision that you find in the stem.
- D) As soon as the regulation is completed, screw the stop set nut again (3) by firmly holding the adjusting bell (2). The set nut must be screwed with a screwing torque of 10 nm (at last). Insert the cover (1) with pressure on the adjusting bell (2).
- E) Put the setting-seal by tying with a wire (4) the cover (1) and the adjusting bell (2), and apply finally the plumbing.

SETTINGS

PN SERIES	15"
R SERIES	18"
PNR SERIES	18"
LC SERIES	25"
PR SERIES	24"
DL SERIES	21"
PVT SERIES	
- PVT200	24"
- PVT400	24"
- PVT1000	24"

SAFETY VALVES - PRESSURE VALVE SETTINGS

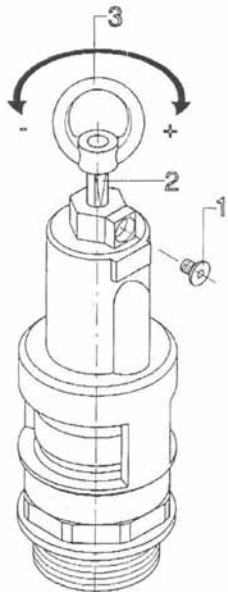

In lack of directions from the Customer, the safety valves are delivered without settings. In this case the setting will be done by the person who install the valve according to the under stated proceedings.

YES!

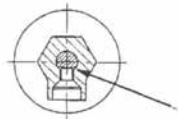

NO!

NO!

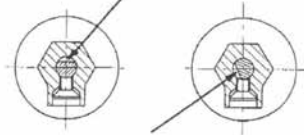

SETTINGS

PN SERIES	12 PSI
R SERIES	14 PSI
PNR SERIES	12 PSI
LC SERIES	16 PSI
PR SERIES	16 PSI
DL SERIES	14 PSI
PVT SERIES	16 PSI

PRESSURE VALVE SETTINGS

After having released the anti-rotation screw (pos. 1) is sufficient to wheel the upper ring (pos. 3) to increase (clockwise rotation) or decrease (anti-clockwise rotation) the setting pressure.

When you have reached the desired pressure, you must verify that the arrow on the stem (pos. 2) lines up to the anti-rotation screw (pos. 1). On the contrary it is necessary to wheel lightly the upper ring till you reach the exact correspondence. At last you have to screw completely the anti-rotation screw (pos. 1) and the setting is completed.

ATTENTION: When setting is over, please verify that the stem can wheel, but can only slide vertically. **DO NOT REPLACE** for no motivations, the standard anti-rotation screw with other types or blocking systems; use exclusively Metaltecnica spare parts.